

MIDAS

TECHNOLOGY, INC

for microelectronic rework since 1986

2011 D5 Series **de-lidder™**



WHAT IS A de-lidder™?

It's a Midas Technology-trademarked system designed to remove lids from hermetic microelectronic packages, so successful that after 24 years, the term **de-lidder™** has become an industry standard.

It mills through lid flanges so precisely that packages can be resealed without further processing. It is clean-room friendly, so packages in rework cycles never leave controlled atmosphere.

The **de-lidder™** system has been adapted to numerous different industries and applications throughout the world, and it is still the unchallenged leader in hermetic lid removal.



WHO NEEDS TO OPEN MICROCIRCUIT PACKAGES?

Every facility involved with high-reliability, high-value packaged electronics wants the capability to open them, whether for rework, quality control or failure analysis.

WHY DO THEY NEED de-lidder™ TECHNOLOGY?

Whatever the application, microcircuits must be opened cleanly, so no particulates contaminate the cavity. They must be handled with a minimum of vibration and stress, and machined so precisely that no significant package material is removed. And to keep product in the cleanroom, the machine must be designed for cleanroom staff, not skilled machinists.

BASICS OF HERMETIC PACKAGE SEALING: A typical hermetic product consists of a nickel-plated metal package (containing electronics) and lid. These are sealed together by a “seam welder” machine which rolls electrodes along two opposite sides of the lid, rapidly pulsing electricity to melt the lid and package plating together. This creates a continuous, airtight bead of nickel between the lid and package. The bead runs from the outside edge of the package about halfway across the package wall.

Key Fact: *The process is designed to keep melted nickel away from the cavity, so there is a width of package wall between the nickel and the cavity that is not affected by the sealer.*

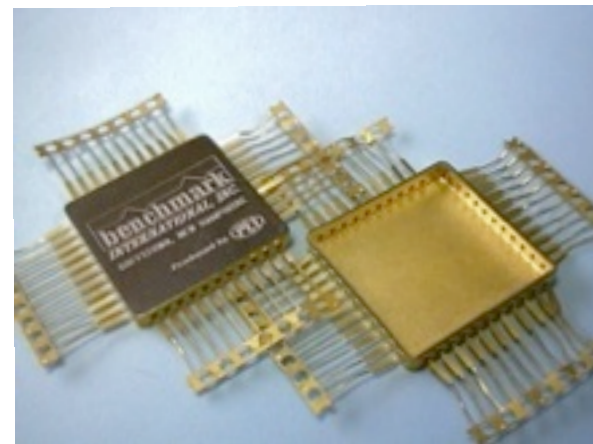

FIVE ESSENTIALS OF THE de-lidder™ PROCESS:

These are things we must control to be successful. This brochure illustrates how we do.

DEPTH: We only want to machine through the lid, not the package wall. To do this we need to precisely control how much of the lid’s thickness we machine through (the depth of cut). To do this we also need a good “zero” height reference.

WIDTH: We can’t expose the cavity to debris, so we won’t machine any part of the lid that is over the cavity. Fortunately, we only have to machine away the attached part of the lid which is away from the cavity. So we need precise control of “width of cut”, and we need a good “zero” width reference.

SURFACE FINISH: We need to leave a good surface finish which will reseal. For this we need an appropriate cutting tool, and we need to provide adjustments to allow the tool to work at its best with typical microelectronic materials.

CLEANLINESS: Microelectronics are vulnerable to contamination by machining lubricants and conductive particles. It can be difficult to successfully clean them out of a package cavity - much easier to keep them out in the first place.

LOW VIBRATION: Normal milling tools and saw blades can create damaging vibration in packages, breaking wire bonds and sensitive components. We have created special high speed tooling to eliminate these traditional problems.

DEPTH OF CUT CONTROL: Every Midas **de-lidder™** since the 1990 DL-4 has featured a height-adjustable tool spindle, with a precision vertical slide and leadscrew. Standard models have about 1" vertical adjustment. This provides range for doing packages on the turntable option and other special configurations described later.

Height is changed simply by turning a top-mounted knob with reference to a dial indicator. The T-handle spindle lock tool (shown at right) can be inserted in the knob for the most sensitive height adjustments ($\pm .0001$ ")

"ZERO" DEPTH OF CUT: For repeatable results, it is critical to have a consistent and accurate "zero". If you try to de-lid on a standard milling machine, you hold the package with the lid facing up, and measure zero at the top of the lid. But packages have wide height tolerances, so unless special leveling steps are taken, you will mill deeper on some places than others. This creates steps that have to be removed by sanding, changing the finished package dimensions. **We have a much better approach!**

LID-DOWN FIXTURING: We flip the package over and set the lid on a precisely level surface. This obviously helps keep debris out - but more importantly, placing the lid on a known level surface gives us an ideal height reference. We set "Zero" depth of cut where the cutting tool is just flush with the work surface; this way it is good for every package.

By locating our cutting tool underneath the package, we can machine just through the flange of the package lid with great consistency, without cutting into the package wall.

NOTE: once you set "zero" depth, you do not need to reset it for different packages.

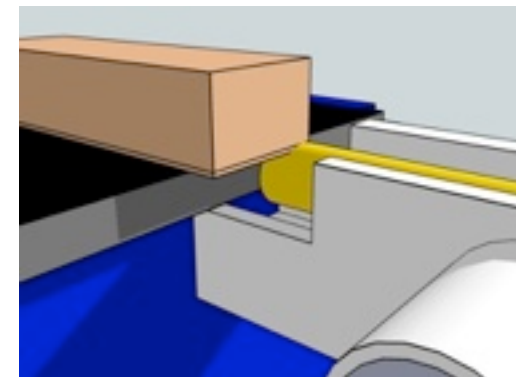

WIDTH OF CUT REFERENCE: Since we do not want to cut all the way across the package wall, but only enough to remove the melted nickel plating, we need to set “zero” width at the outside edge of the package. We have an easy way to do that.

“DATUM STOP” FIXTURE: Our machines include a stop, or fence, fixture. Each package side is pushed against this stop, locating it in precisely with respect to the cutting tool. These fixtures can be simple straight edges, or quite complex machined pieces with cutouts for specific package features - the important thing is when the side of a package is set against the stop, it will be aligned properly with the cutting tool.

ADJUSTING WIDTH OF CUT: The cutter position is fixed, so to adjust how much we cut in from the side of the package, we adjust the position of the datum stop. It slides forward and back on a rail, as an operator knob on the worktable is turned. The operator can see on the attached dial indicator exactly how much of the package will be cut,.

“ZERO” WIDTH OF CUT: The indicator is normally set to “zero” when the fixture edge is exactly over the operator side of the cutting tool - at the position where the cutting tool only brushes the side of the package.

NOTE: Once you set “zero” width on the standard fixture, you do not need to change it for different size packages.

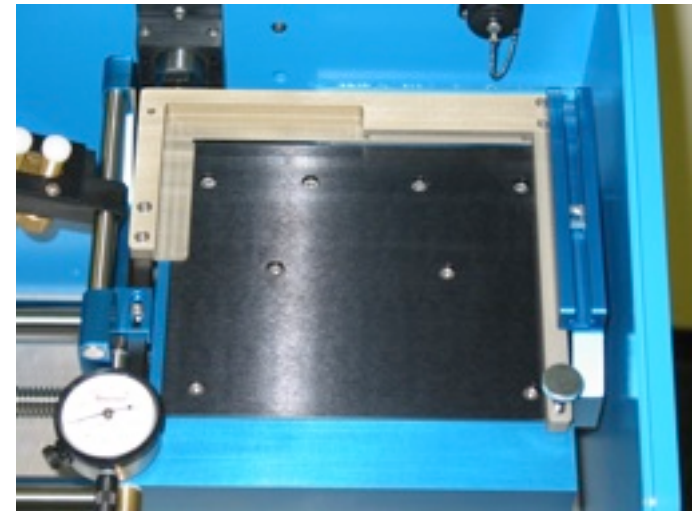
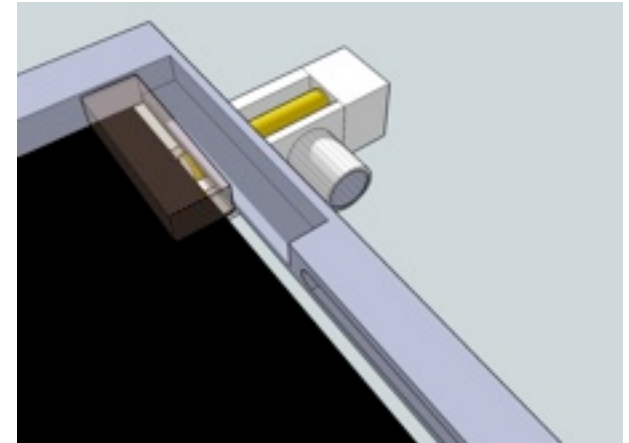

SURFACE FINISH

RESEALABLE SURFACE FINISH: is achieved by a combination of tool geometry, tool orientation, speed settings, and high quality, smooth-running tool and work table drive systems.

In the surface analysis at right, the finish of the original gold plating is graphed above a comparable section of our machined surface. In this sample, the machined surface actually appears smoother; it is certainly comparable.

The photo at right shows a 1mm (.040") wide de-lidded package wall. The gold plating (toward the top) has not been touched. The machined surface (below the gold) shows tool marks. During reseal, nickel from the new lid will flow into and along these tool marks actually enhancing the seal quality. Since our tool marks add to sealability, and our flatness specifications exceed those for virgin packages, it is not surprising that reseal yields for de-lidded packages are equivalent to new package yields.

nanofocus[®]
see more

MIDAS Technology
Butterfly package
µsurf professional

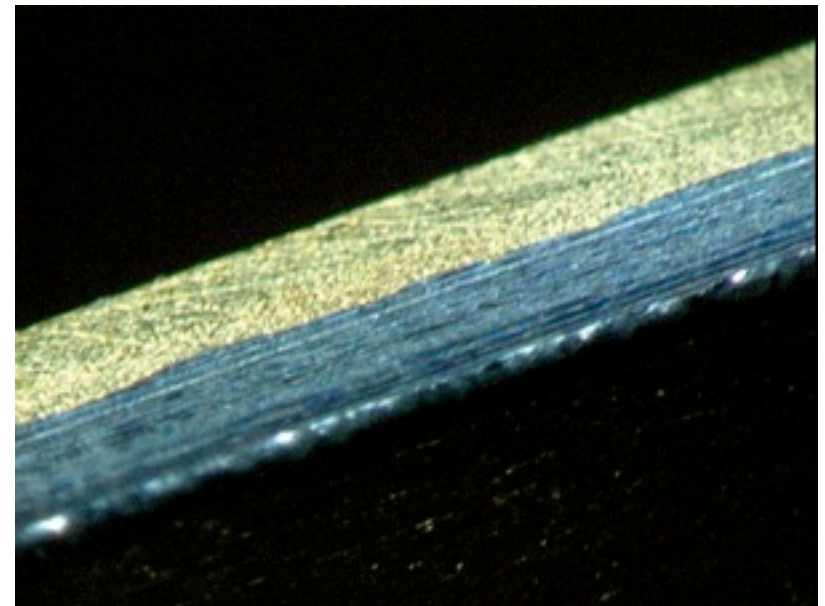
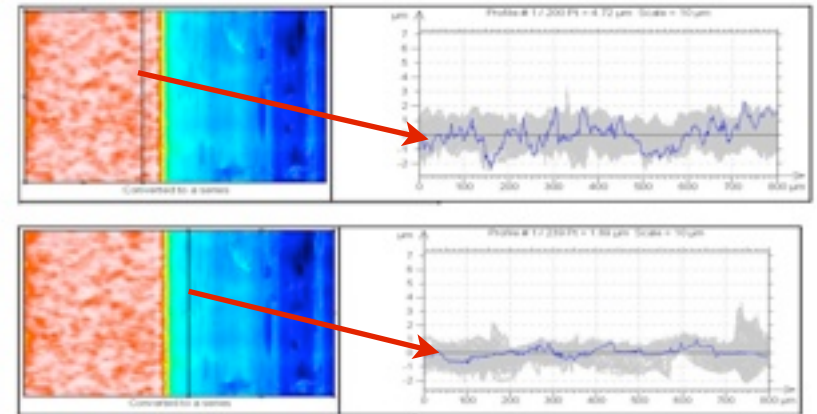

NOTE: this photo also shows how well our machine controls depth and width of cut; exactly matching the original gold surface and staying parallel to the cavity.

CLEANLINESS: in de-lid terms means that we protect the package and cavity from lubricants and particles created by machining.

The first problem, lubricants, is easily dealt with. We have created a dry (air cooled) machining process using Titanium Nitride-coated tools.

The second problem, protection from particulates, is more difficult. We tackle this in several complementary ways.

- **GRAVITY** the lid facing down helps keep debris out.
- **MECHANICAL SEAL** we press the lid down against the inside package wall to keep debris out of the cavity
- **VACUUM** We provide high vacuum around the cutting tool to pull contaminants away from the package
- **TOOL GEOMETRY** twists away from the package, so particles are pulled from the package, not forced into it.
- **ENVIRONMENT** Our unit is designed for use in cleanrooms, so your packages never encounter machine-shop conditions.

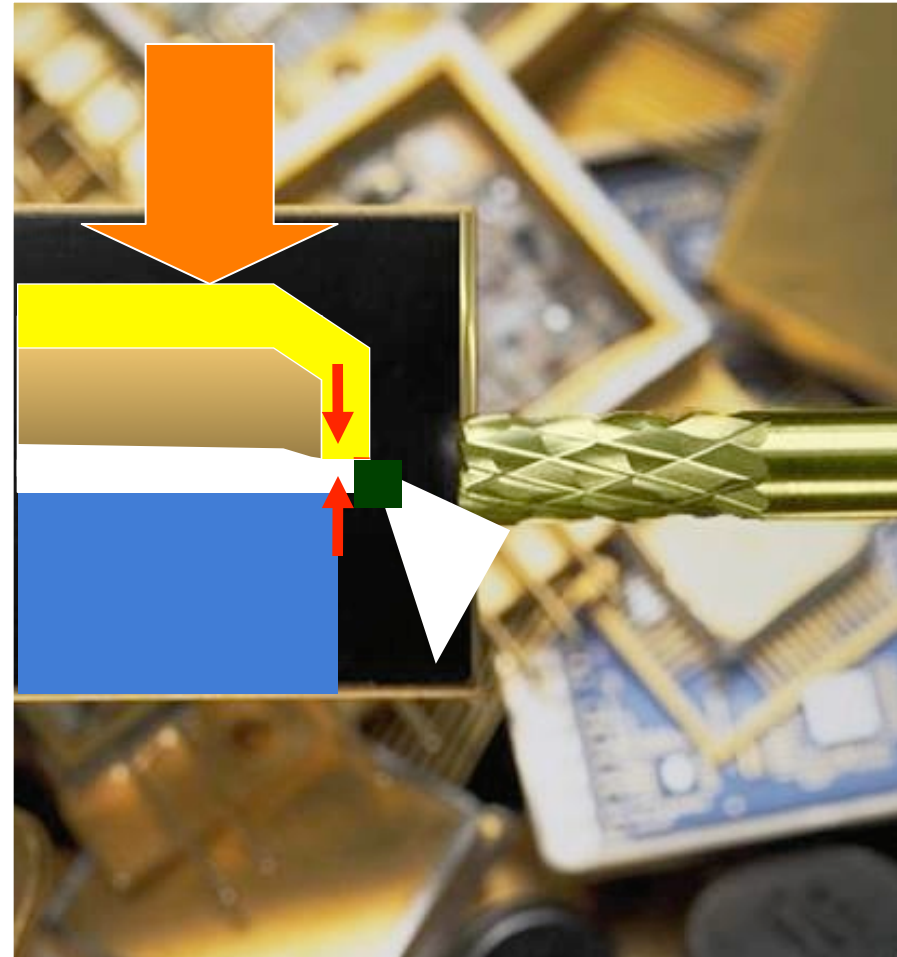

LOW VIBRATION: The most critical source of vibration in the de-lid process comes primarily from the contact of cutting flutes with the package lid. This was an industry-wide problem when Midas entered the industry, and our successful solutions led us rapidly to market leadership.

- **LOW IMPACT:** our cutting system is designed to reduce impact on the package by turning the cutting tool in the same direction as the package is moved (i.e. “Ramp” milling) and by removing a very small amount of material with each contact.
- **HIGH FREQUENCY,** for many years we’ve pushed vibration beyond wire bond damage range by using high flute count tools and high cutter speeds.
- **RESONANCE DAMPING** most recently we have added a higher speed tool (ASHO8 Asynchronous Helix™) which adds variable flute spacing to eliminate resonance and reduce tool wear.
- **CHATTER DAMPING** Our holddown system provides adjustable force (allowing consistent, maximum safe pressure on the device) with a mechanically soft, non-elastic interface.
- **MACHINE MASS** The entire de-lidder™ machine is massive and thoroughly bolted into a rigid assembly; the heavy carriage and table assembly blocks virtually all drivetrain vibration from the package.

PANEL

- **CUTTER SPEED:** determines spindle speed through belt drive, normal range in kovar and similar materials is 90-96 (on DL-4A shown, max is 6930, on D5 about 8400 RPM). *Rarely changed unless different materials are used.*
- **FEED RATE,** shows table speed in inches per second. Normal is 1.0-1.5
- **STROKE SIZE** how far table will travel, from edge of fixture to auto return, *also used with START button to re-program table home position to any desired point.*
- **START** initiates cutting sequence, *also used on power-up to program "Datum Offset" -resets table "home" to any desired position.*
- **HOME** returns table to starting position, *also used on power-up to toggle "HomeRun™" dual-direction cutting and vacuum feature.*
- **ON-OFF** Machine power, *ON used with HOME and START for programming.*



HOLDDOWN:

- **TORQUE LIMITER** adjusts to provide consistent, safe clamping force suitable for rigid metal packages as well as more fragile ceramics and MCMs.
- **HOLDDOWN FEET** are provided in three sizes to suit small DIPs and large modules.

TOOL PATH:

- **DEPTH & WIDTH OF CUT** Knobs and Indicators discussed on previous pages

Series 5 de-lidder™ Design Features

NEW CONSTRUCTION FEATURES

- **IMPROVED CARRIAGE ASSEMBLY** on flat rails; massive unitized structure holds to .0002" flatness; *replaces DL-4A and earlier dual round rails and trestle supports.*
- **IMPROVED TABLE DRIVE** with programmable, plug & play replaceable servomotor; *replaces worm gear/potentiometer and voltage comparator circuits, and limit switches*
- **IMPROVED POSITIONING** using permanent hard stop and home position reset on boot-up, *speeds cutter changes and eliminates electrical setup following maintenance/repairs.*
- **IMPROVED CHASSIS.** with heavier frame and more rigid, 3-D interlocking assembly design
- **IMPROVED CUTTER DRIVE** upgraded higher speed motor and turning components
- **IMPROVED SERVICEABILITY** with central relay circuit board, panel lamp error code diagnostics

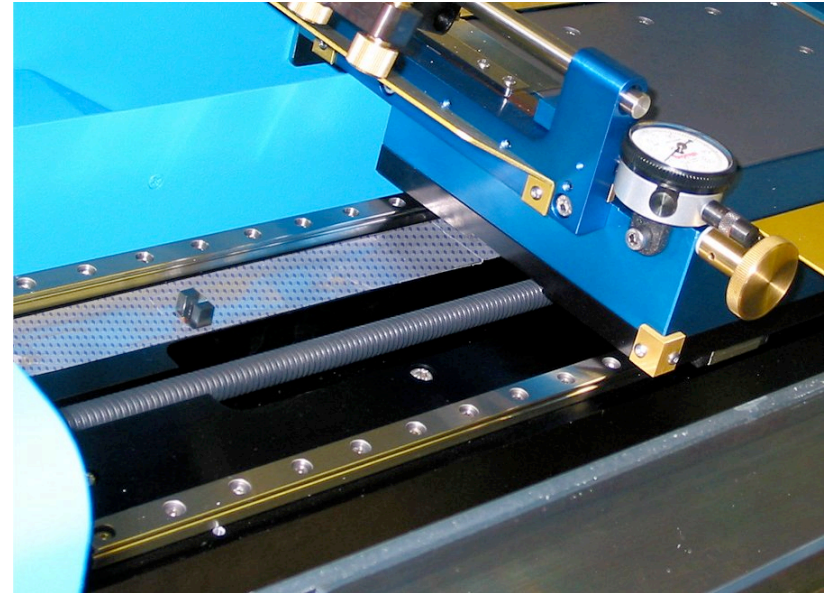

NEW PANEL SELECTABLE FEATURES

- **HOMERUN** home stroke (bidirectional) cutting with vacuum, can improve surface finish and add protection from particle intrusion during home stroke
- **DATUM OFFSET** relocates table home position to any desired point, so tool is closer to package on start - reduced process time

Series D5 de-lidder™ Setup Options

PACKAGE ON WORKSURFACE, LID DOWN, TOOL BELOW Our standard, most precise configuration, suitable for bathtub, plug-in, butterfly, and all other straight-sided packages with “external” seam-sealed flat lids. The top of our cutting tool is raised above the worksurface just enough to mill through the lid flange. Depth of cut is limited by clearance (normally .011”-.015”, more if needed) between the datum stop and the top of the cutting tool. Simple slots and notches can accommodate features on package sides.

By changing to a “datum backstop” referencing the operator side of the package, depth of cut range is not limited. A backstop is also a good solution for packages with very low seal rings which do not allow the .050” required for a durable mechanical shelf.

PACKAGE ON FIXTURE, LID DOWN, TOOL BELOW When package features such as pins or connectors extend below the seal plane, we can mount a “datum plate” fixture with pockets to correctly position the package, and expose each cutting edge. The added fixture affects depth of cut accuracy slightly, and reduces vertical holddown clearance which may require minor modifications.

When additional vertical “reach” is required we provide sawblade and arbor sets which fit the standard D5 tool spindle. For more clearance between the tool tip and the spindle (untrimmed lead frames, for example) we have the larger chassis D5F series.

PACKAGE ON FIXTURE, LID UP, TOOL ABOVE Formed metal covers are rarely precise, so they will not sit flat when placed lid down. They are usually sealed to headers, which have pins underneath. The solution is to mount the package with the cover facing up, with the pins down into a fixture. We raise the cutting tool and mill through the cap flange with the bottom of the tool. Reseal is dependent on the flatness of the header. If the header cannot be made to sit flat on the fixture, the tool will cut into the header where it lifts up.

This is also the basic configuration for round parts done on our D5L6 Turntable Module; each part requires a platter fixture which holds it in the exact center of rotation.

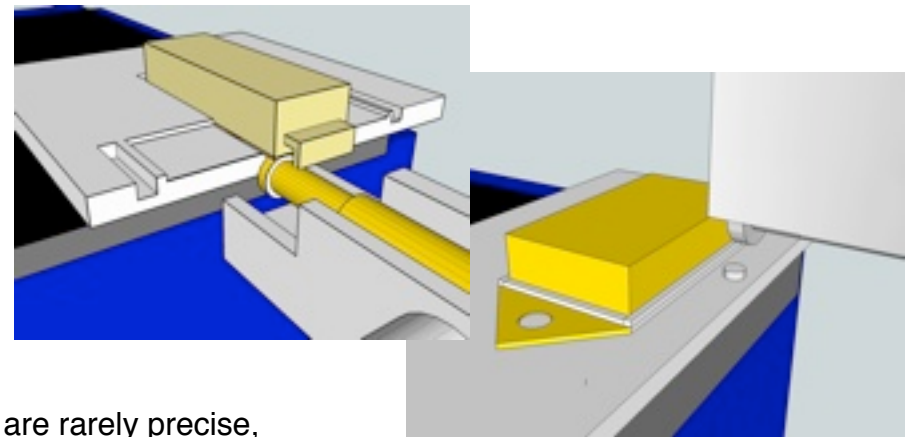
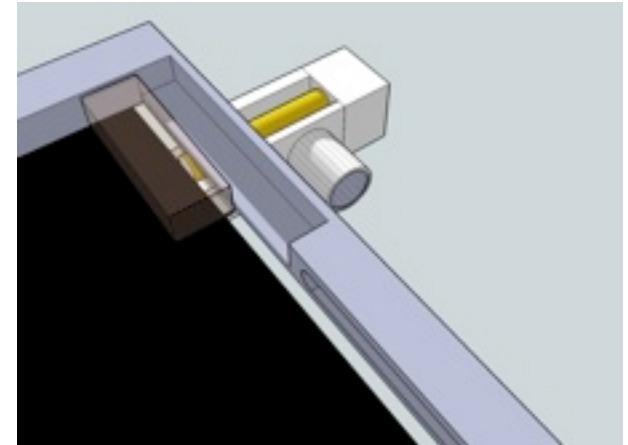

Series 5 de-lidder™ Tool Options

MILLS We provide two lines of milling tools, both TiN coated for clean cutting and longer life.

- The original dual helix design works best at the slower spindle speeds of DL-3 and DL-4 machines, and on turntables. It also works fine on D5 series machines, but at reduced spindle speed settings.
- The new ASH08 “Asynschronous Helix” has fewer, thicker, and more durable flutes, with variable spacing to control resonant vibration. It works best with high D5 spindle speeds.

MILL OPTIONS We provide extended flute and/or shank lengths (photo, center left), “T” shaped or “profiled” tools (center right), and different shank diameters (standard 8mm, 6mm for more clearance, 10mm for more rigidity)

BLADES When more tool reach is necessary (up under power hybrid leads, for example) we can mount sawblades (lower right) on arbors (upper right) which fit our spindles.

GRINDING TOOLS For special applications (ceramic lids, glass) we can provide Borazon or diamond-coated disks and drum shapes to customer-specified dimensions.



ASH08 "Asynschronous Helix™"

Due to our policy of continual improvement, all specifications and prices are subject to change. Export equipment requires physical modifications and additional charges. Distributor support is available in most world markets. Please contact us for a review of your application requirements and a detailed quotation.

Series 5 de-lidder™ Models

D5L SERIES for aerospace hybrids, DIPs, bathtub packages
Includes combo shelf & slot datum stop

D5L6 Travel 6"
D5L8 Travel 8"
D5L12 Travel 12'



D5F SERIES for packages with attached optical fiber
includes low profile steel datum stop, fiber protective trays,
and extra spindle clearance to reduce fiber bending

D5F6 Travel 6"
D5F8 Travel 8"

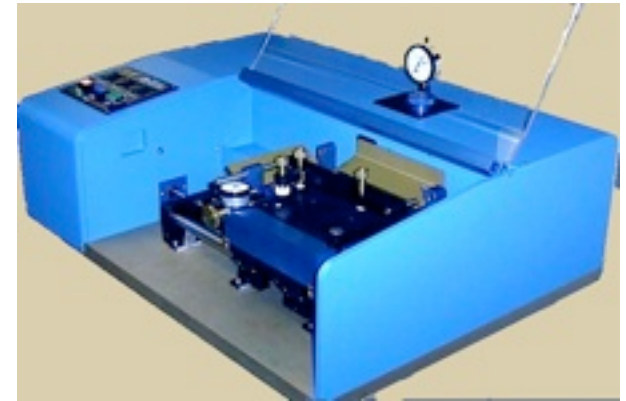

D5R SERIES for round packages

Turntable accepts parts up to 3"d,
pins to .75" long

Dedicated machine accepts 3" parts,
max lead length can exceed 1.5"

D5RT Turntable Module for D5L, D5F

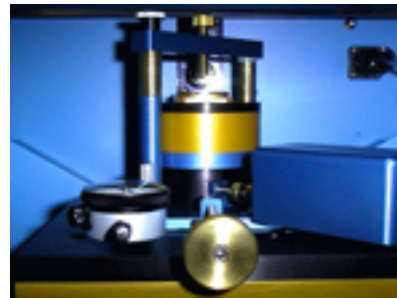

D5R3 Dedicated Rotary Machine



ABOUT US

We're a privately-held specialty manufacturer incorporated in 1986, operating since 1987 in a modern industrial park north of Boston, MA, USA. Our products are marketed and supported by a world-wide network of exclusive regional representatives and distributors.



de-lidder™ machines remove lids from hermetic packages non-destructively, leaving a particle-free cavity and reseal-ready surface so product can be reworked and resealed. We have multipurpose and dedicated models for rectangular, round, and optical fiber modules.



HGRS *HOT* Gas Workstations safely remove components from assembled circuits with momentary jets of precisely localized very hot Nitrogen. A full suite of tools also make these machines the ideal “thermal workbench” for prototypes & advanced applications.

We sell to manufacturers and users of high-value, high-reliability microelectronics. As microelectronic packaging technologies have spread from **defense/aerospace** into **telecommunications**, **optoelectronics**, and **medicine**, our customer base has expanded into all these fields world-wide; wherever the time and materials invested in such products make them worth reworking.

for answers to any technical questions and a technical review of your application. Our regional representatives can help you arrange samples and demonstrations.

CONTACT US

MIDAS
TECHNOLOGY, INC

for microelectronic rework since 1986

400 West Cummings Park, Suite 6400

Woburn MA 01801-6513 USA

www.midastechnology.com

Email us: sales@midastechnology.com

Tel +1 781-938-0069 Fax +1 781-938-0160

